

ABN: 85164277052
HAPP AUSTRALIA PTY LTD



Specification

WWW.HAPP.COM.AU

2.7 Tonne

HAPP 10



Electric - Hydraulic lift

Movable - Scissor lift

Features

- Carriages moves synchronously , Dual Hydraulic cylinder drive, stable lifting and lowering
- Movable, hook pump trolley to lift and roll (best if slightly raised)
- Ratchet safety mechanism multiple safe working positions
- Dynamically tested with 125% of rated capacity and static test with 150% of rated capacity
- Flat packaged fully assembled for easy installation
- Wide base gives stable lifting
- Simple installation, unpack and go
- CE certified (Europe and USA)
- 5mm thick top plates
- 16mm thick lift plate
- 1.4m lift height
- Trolley and pump assembly included
- Connector to external limit switch
- 12 month manufacturer parts warranty
- Access to HAPP customer group buy plan
- Many options available:
 - ❖ Low profile car ramps for very low cars
 - ❖ Oil drains for cleaner oil change operation
 - ❖ Spare motors, control valves ...

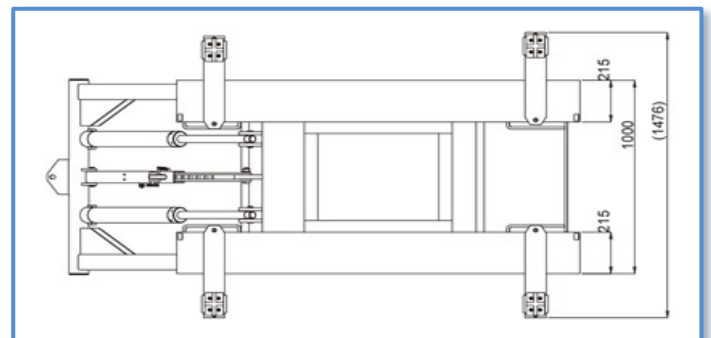
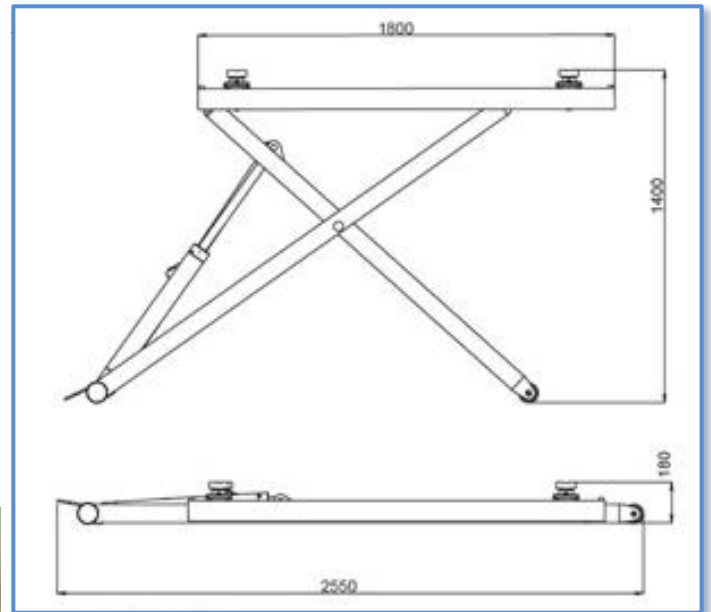

Capacity	Lifting Height *	Rise Time	Drop Time	Power Supply	Width of rack	Length of rack	Height of rack	Pillar Width	Net Weight
2.7T	1400mm	<50s	>20s	240/415v-15A	1476mm	2550 mm	130mm	2910mm	478Kg