

ABN: 85164277052
HAPP AUSTRALIA PTY LTD



Specification

WWW.HAPP.COM.AU

4 Tonne

HAPP 70

Business Ready

2 Post Electric - Hydraulic lift

Floor plate – Single point safety release

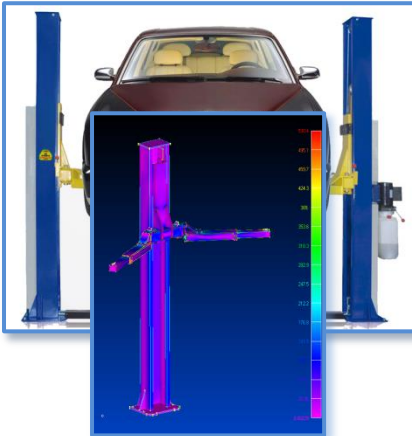

Features

- Australian Standards **Tested** and **Certified**
- Ready for use in businesses, Workplace Health and safety registration kit available
- Release both column safeties from single point
- Carriages move synchronously, Dual Hydraulic cylinder drive, stable lifting and lowering
- Dynamically tested with 125% of rated capacity and static test with 150% of rated capacity
- CE certified (Europe and USA)
- 5mm thick columns
- 16mm thick base plate
- 20mm Tru-bolt design anchor bolts
- HAPP Ultra strong arms
- HAPP Screw up drop in pad design
- HAPP Ultra strong carriage
- 2" + 6" spacers standard
- Connector to external limit switch
- 12 month manufacturer parts warranty
- Access to HAPP customer group buy plan
- Many options available:
 - ❖ Extra stability; big base plates, stabilizer bars
 - ❖ Low profile car ramps for very low cars
 - ❖ Oil drains for cleaner oil change operation
 - ❖ Alternate anchor bolts, extra spacers, spare motors ...

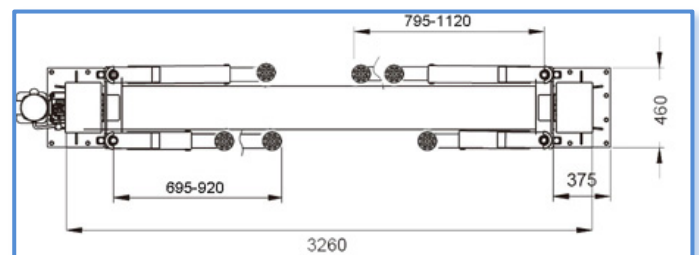
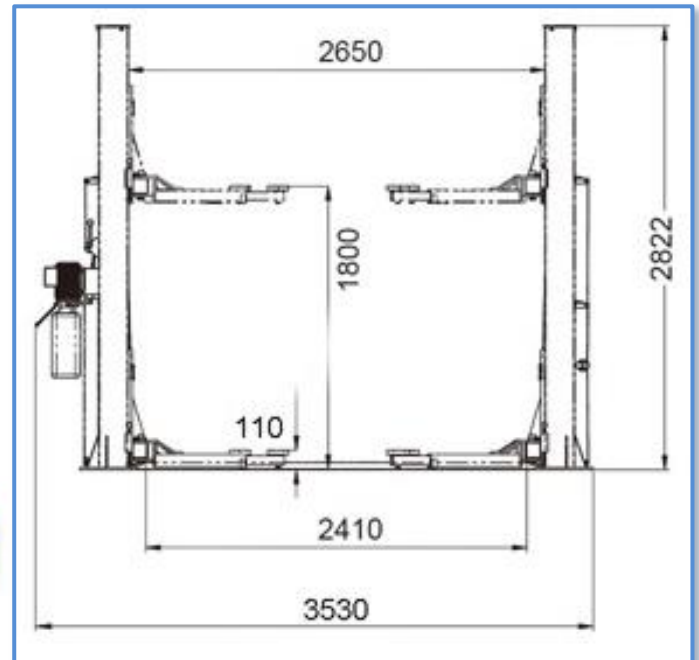

Capacity	Lifting Height*	Rise Time	Drop Time	Power Supply	Width of rack	Height of rack	Width at base plate	Pillar Width	Net Weight
4.0T	1800mm	<50s	>20s	240/415v-15A	3260mm	2822 mm	3442mm	2650mm	592Kg