

ABN: 85164277052  
HAPP AUSTRALIA PTY LTD



WWW.HAPP.COM.AU

3 Tonne

Specification

# HAPP 90

2 Post Electric - Hydraulic lift

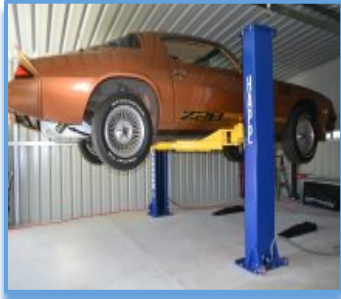

Clear floor – Movable - Two side multi point safety latch

## Features

- All hydraulic balance control, clear floor, no balance control cables
- Low 2.02m height columns
- Work safely at multiple lift heights with HAPP standard ratchet safety mechanism
- Install in multiple locations with movable columns
- Dual Hydraulic cylinder drive, stable lifting and lowering
- Dynamically tested with 125% of rated capacity and static test with 150% of rated capacity
- CE certified (Europe and USA)
- 5mm thick columns
- 16mm thick base plate
- 16mm Loxon bolt design anchor bolts
- HAPP Ultra strong arms
- HAPP Screw up drop in pad design
- HAPP Ultra strong carriage
- 2" + 6" spacers standard
- Connector to external limit switch
- 12 month manufacturer parts warranty
- Access to HAPP customer group buy plan
- Standard steel tank + aluminium motor
- Many options available:
  - ❖ Extra stability; big base plates, stabilizer bars
  - ❖ Low profile car ramps for very low cars
  - ❖ Oil drains for cleaner oil change operation
  - ❖ Alternate anchor bolts, extra spacers, spare motors ...

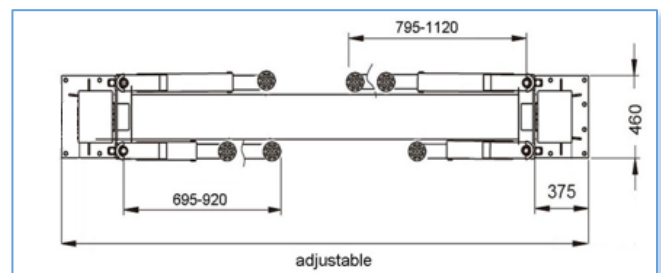
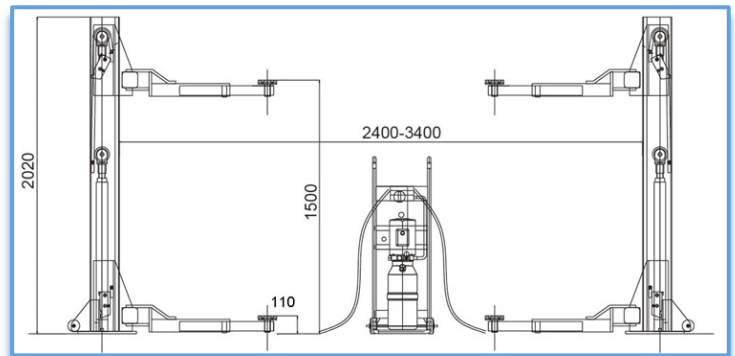

Capacity	Lifting Height	Rise Time	Drop Time	Power of Motor	Power Supply	Width of rack	Height of rack	Width at base plate	Net Weight
3.0T	1500mm	<40s	>20s	2.2 Kw	240v/ 415v	adjustable	2020mm	adjustable	450Kg