

ABN: 85164277052
HAPP AUSTRALIA PTY LTD



WWW.HAPP.COM.AU

3 Tonne

Specification



HAPP 95

High Lift 2 Post Electric - Hydraulic hoist

Clear floor – No overhead beam - Movable - Two side multi point safety latch



Features

- All hydraulic balance control, clear floor, no balance control cables, no overhead beam
- Low 2.4m height columns
- High 1750mm lift height (more with spacers)
- Work safely at multiple lift heights with HAPP standard ratchet safety mechanism
- Install in multiple locations
- Dual Hydraulic cylinder drive, stable lifting and lowering
- Dynamically tested with 125% of rated capacity and static test with 150% of rated capacity
- 5mm thick columns
- 16mm thick base plate
- 16mm Loxon bolt design anchor bolts - optional
- HAPP Ultra strong arms
- HAPP Screw up drop in pad design
- HAPP Ultra strong carriage
- 2" + 6" spacers standard
- Connector to external limit switch
- 12 month manufacturer parts warranty
- Access to HAPP customer group buy plan
- Standard steel tank + aluminium motor – 15A, 240V, Single Phase (3 phase optional)
- Many options available:
 - ❖ Extra stability; big base plates, stabilizer bars
 - ❖ Low profile car ramps for very low cars
 - ❖ Oil drains for cleaner oil change operation
 - ❖ Alternate anchor bolts, extra spacers, spare motors ...
 - ❖ Wheel kits to assist in moving hoist around

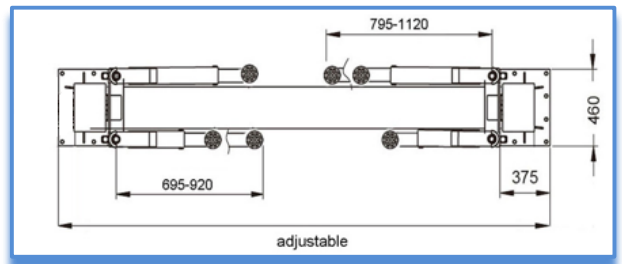
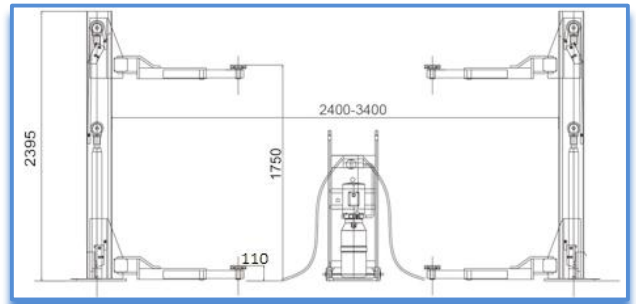

Capacity	Lifting Height	Rise Time	Drop Time	Power of Motor	Power Supply	Width of rack	Height of rack	Width at base plate	Net Weight
3.0T	1750mm	<40s	>20s	2.2 Kw	240v/ 415v	adjustable	2420mm	adjustable	500Kg