



Specification



2.7 Tonne

HAPP 10



Electric - Hydraulic lift
Movable - Scissor lift

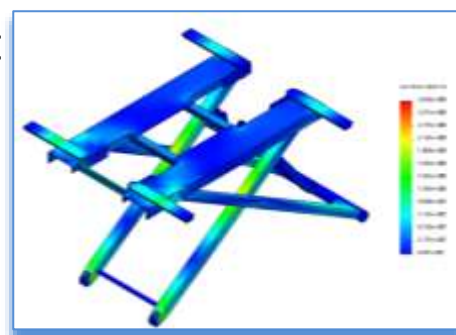

Features

- Carriages moves synchronously, Dual Hydraulic cylinder drive, stable lifting and lowering
- Movable, hook pump trolley to lift and roll (best if slightly raised)
- Tested and certified to Australian Standards in Queensland by Queensland engineers.
- Ratchet safety mechanism multiple safe working positions
- Dynamically tested with 125% of rated capacity and static test with 150% of rated capacity
- Flat packaged fully assembled for easy installation
- Wide base gives stable lifting
- Simple installation, unpack and go
- CE certified (Europe and USA)
- 5mm thick top plates
- Trolley and pump assembly included
- Connector to external limit switch
- **3 year structural warranty - happ.com.au/warranty/**
- Many options available:
 - ❖ Low profile car ramps for very low cars
 - ❖ Oil drains for cleaner oil change operation
 - ❖ Spare motors, control valves ...

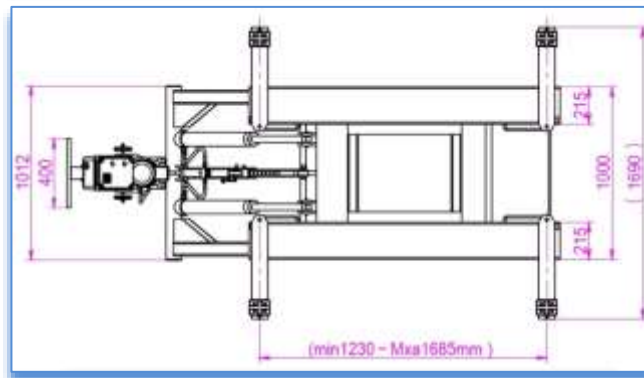
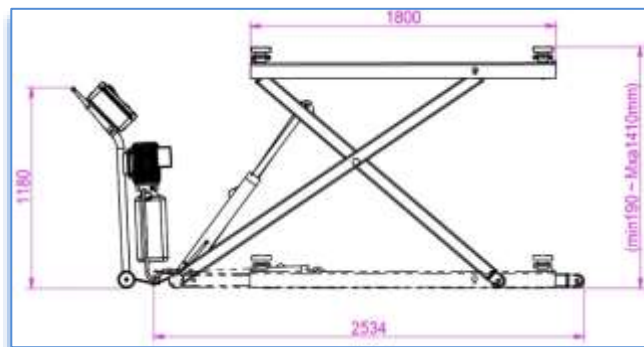

| Capacity | Lifting Height * | Rise Time | Drop Time | Power Supply | Width of rack | Length of rack | Height of rack | Pillar Width | Net Weight |
|----------|------------------|-----------|-----------|--------------|---------------|----------------|----------------|--------------|------------|
| 2.7T | 1410mm | <50s | >20s | 240/415v-15A | 1012mm | 2534 mm | 190mm | 2910mm | 478Kg |