



ABN: 85164277052
HAPP AUSTRALIA PTY LTD



WWW.HAPP.COM.AU

3 Tonne



Specification

HAPP 12



Moveable full height scissor lift – electric release
Optimised for ease of use – no air supply required.

Features

- Dual Hydraulic cylinder drive, stable lifting and lowering
- HAPP Australian Standard designs – designed verified against AS1418.9 and many other Australian Standards by Queensland engineers.
- Precision CNC controlled cutting and Robot welding provide highest quality product.
- Electric release solenoids, no need for air to operate lift.
- Variable rate arms ensure even heavy vehicles can lift from ground.
- Control unit is of exceptional quality to other lift suppliers
- Moveable control unit and lift
- High grade scissor beams exceed Australian standards
- Toe protection guards
- Anti slip tread plates
- Latches, pins and locking ladder use premium steel grades that exceed Australian standards
- Dynamically tested with 125% of rated capacity and static test with 150% of rated capacity
- Upgrade from CE certified (Europe and USA) with HAPP Aus Std designs
- Electronic max height limit switch
- 3 yr structural warranty - happ.com.au/warranty/
- Access to HAPP customer group buy plan

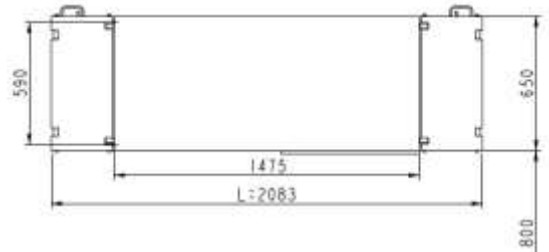
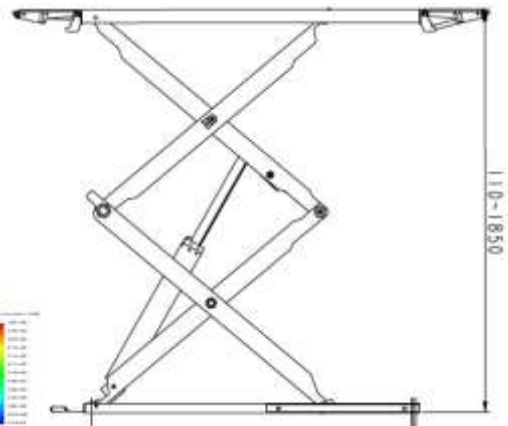

Colour is blue platform / base and grey scissor
Heavy use users use the HAPP 12A with air solenoids

Capacity	Lifting Height	Min Height	Power Supply	Length	Table length	Width	Middle Gap	Runway Width	Net Weight
3.0T	1850mm	110mm	240v-15A	2083mm	1475mm	2100mm	800mm	650mm	600Kg

Specifications are subject to change without notice. Contact HAPP for additional details.